



Committed to pumps since 1919 we'll keep evolving and making the world a better place.



General Catalog

Pump Products Guide

Evolving to meet the demands of an ever-changing world.

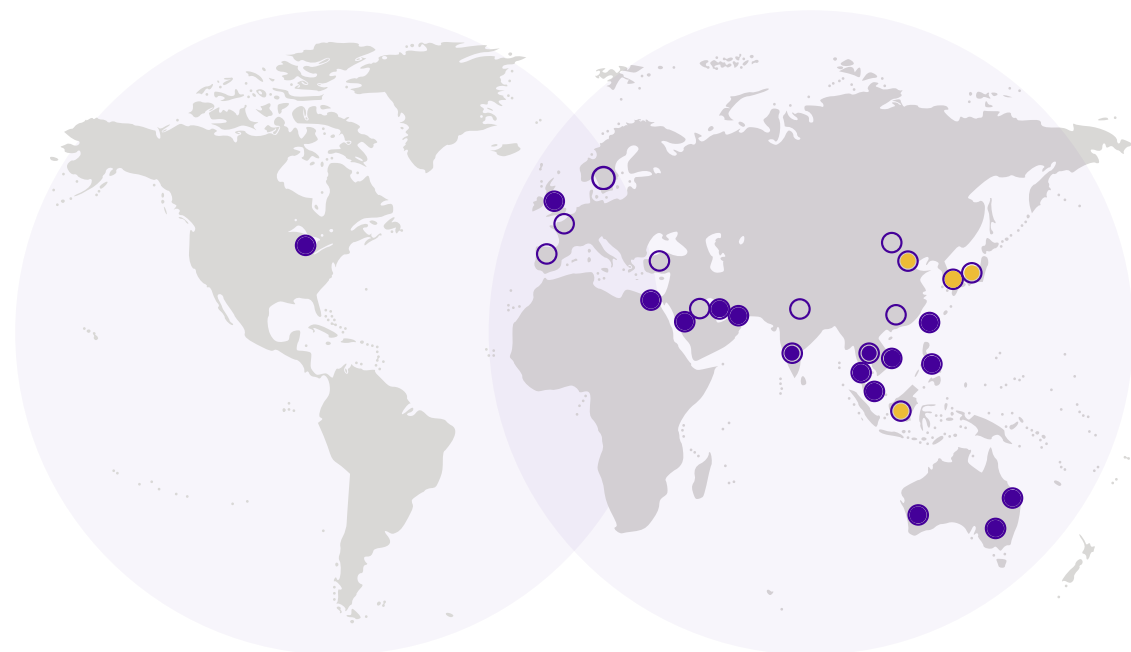

○ Office ● Service centre ● Manufacturing

torishima.co.uk



TORISHIMA is a leading pump manufacturer, founded in 1919 in Osaka, Japan. Our primary objective is to contribute to society as a quality provider of pumping equipment and services. We continue to strive to be the market leader in our field. Our on-going investment in research and development highlights our commitment to provide the best technology for our customers. Our mission is always to listen to our customers, understand their needs and meet their expectations.

Content

- Torishima Main Pumps Selection Table 2
- Chart for Selecting Pumps by Application
- Energy Industry 3
- Municipal Water Works, Industrial Water Works
- Small Capacity Water Works, Desalination Plant ... 5
- Sewerage, Agriculture, Irrigation, River Water 7
- Regional Development, Urban Development 9
- Chemical Industry 11
- General Industry 13

Main Pumps List

- End-Suction Pumps 15
- Double-Suction Pumps 19
- Multi-Stage Pumps 20
- Specialized Pumps 22
- Mixed-Flow Pumps 23
- Axial-Flow Pumps 24
- Submersible Pumps 25
- Miscellaneous Pumps 27
- Mechanical Seals 29
- Service Solutions 30

TORISHIMA MAIN PUMPS SELECTION TABLE

Pumps for Fresh Water

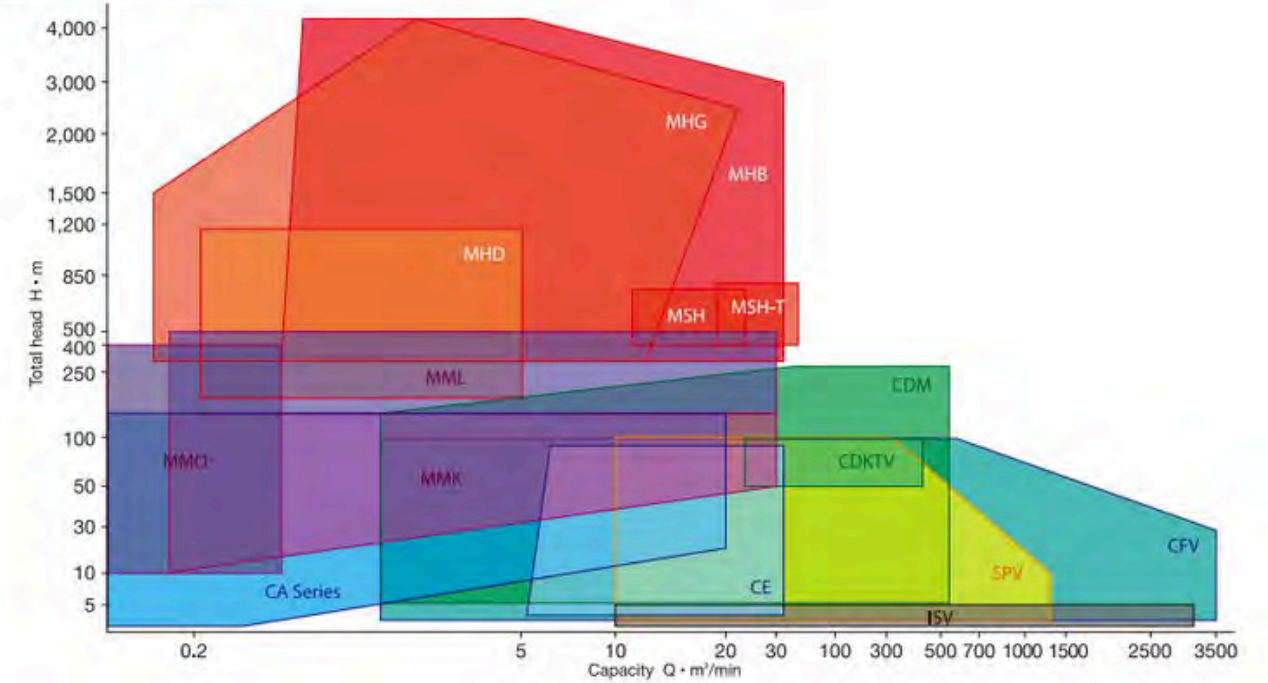

Chemical Process Pumps

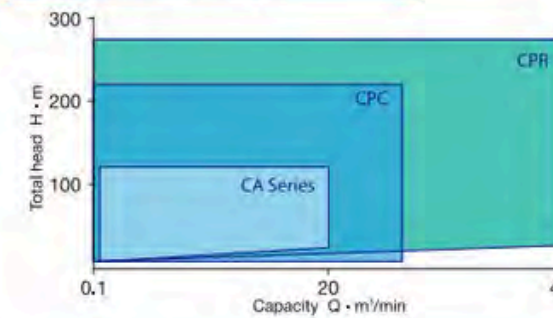

Hot Water / Oil Circulating Pumps

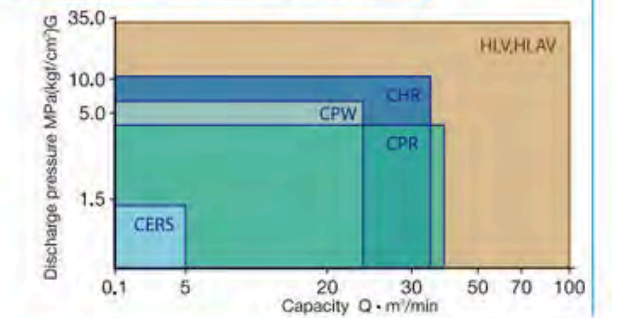

Non-Clogging Pumps

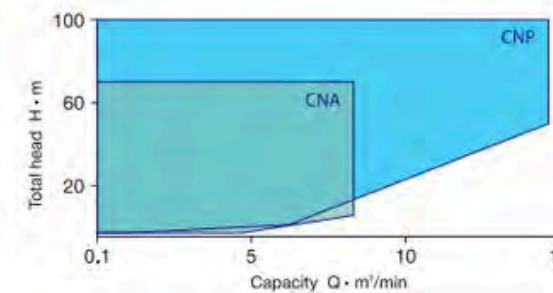

Vertical Pumps for Chemical Industries

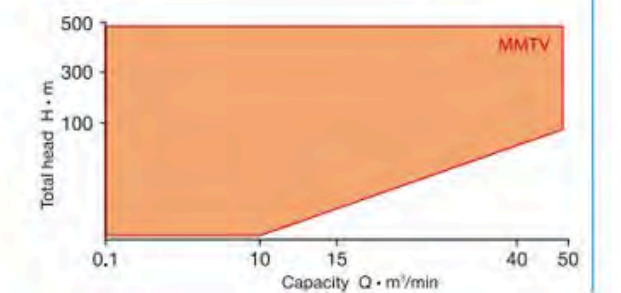

Power Industry



We understand that the demand for energy continues to grow globally. To meet this growing need, the number of new power plants and the refurbishment of existing ones will continue to increase.

We are prepared to offer a complete range of pumps specifically designed for various applications within the power industry, ranging from small combined cycle power plants to large thermal power plants.



Power Industry

Chart for selecting Pumps by Application

Main Application: Horizontal, Vertical, Horizontal/Vertical
 Secondary Application: Horizontal, Vertical, Horizontal/Vertical

Products	Applications											mm	m³/h	m	MPa	°C	Page	
	Power Generation			Gas			Oil Storage (Underground Tank / Ground Tank)		Crude oil	Fire-Fighting	Utility							
	Coal	LNG	Oil	Hydropower	Geothermal	Utility	LNG, LPG	Cooling by Seawater				Oil Product Outlet	Stripping	Underground Water Drainage	Sizes	Max. Capacities	Max. Total Heads	Max. Operating Pressure
End-Suction Pumps	CAL, CAR					●						32 to 200	600	100	1	80	15	
	CAM, CAS	●	●	●	●	●	●	●				32 to 250	1200	150	1.6	80	16	
	CE					●						200 to 300	2100	90	1	140	16	
	CHR	●	●	●								50 to 300	1940	125	10.8	325	17	
	CNP						●					50 to 200	850	100	1	250	18	
	CPC	●	●	●	●		●	●	●				32 to 250	1560	220	2.45	350	18
	CPR	●	●	●	●		●	●	●				25 to 400	2400	270	4	400	18
	CPW	●	●	●									40 to 250	1440	200	6.3	280	18
Double-Suction Pumps	CDM, CDMV	●	●	●	●	●		●	●			200 to 1400	33000	300	3	80	19	
	CDKY	●	●	●								400	3480	160	3.2	210	19	
	CDKTV					●						500 to 1500	20000	100		100	19	
Multi-Stage Pumps	MHB	●	●	●								80 to 200	2000	4200	42	200	20	
	MHG, MHG-A	●	●	●								40 to 300	1400	4200	36	200	20	
	MHD	●	●	●								80 to 200	300	1200	14	180	20	
	MMK	●	●	●			●					40 to 350	1000	150	5.4	230	21	
	MML	●	●	●			●					40 to 350	1000	500	5.4	230	21	
	MMTV	●	●	●		●		●				40 to 400	2900	390	3.9	200	22	
Specialized Mixed-Flow Pumps	HLV, HLAV	●	●	●								40 to 400	6000	180	32	420	22	
	SPV	●	●	●				●				300 to 2800	80000	100		80	23	
Submersible Pumps	SMRV					●		●	●	●	●	150 to 1000	9000	70			25	
	T/B					●						50 to 800	4800	40		40	26	
	F/TB				●	●					●	25 to 200	400	200			26	

Water Industry



The demand for water has grown exponentially over the last few decades and will continue to do so in the decades to come. For this reason, one of the cornerstones of our business from the very beginning has been to offer reliable, high quality and efficient pumping equipment for the responsible supply and use of water.

Water Industry & Desalination

Chart for selecting Pumps by Application

Main Application: Horizontal, Vertical, Horizontal/Vertical
 Secondary Application: Horizontal, Vertical, Horizontal/Vertical

Products	Applications											mm	m ³ /h	m	MPa	°C	Page		
	Municipal Waterworks	Industrial Waterworks	Small Scale Waterworks	Seawater Desalination (MSF)			Seawater Desalination (RO)												
	Intake	Supply	Distribution	Brine Recirculation	Brine Blow Down	Seawater Feed	Product Water	High Pressure Feed	Filtered Water	Back Wash	Product Water	ERD Booster	Sizes	Max. Capacities	Max. Total Heads	Max. Operating Pressure	Max. Operating Temperature		
End-Suction Pumps	CAL	●	●	●					●	●	●		32 to 300	600	100	1	80	15	
	CAR								●		●		32 to 200	600	100	1	80	15	
	CAM	●	●	●					●	●	●		32 to 250	1200	150	1.6	80	16	
	CAS								●		●		32 to 250	1200	150	1.6	80	16	
	CBR											●	125 to 400	2000	70	8	80	16	
	CFV	●	●	●										150 to 5000	210000	100			16
	CPC						●	●	●	●		●		32 to 250	1560	220	2.45	350	18
Double-Suction Pumps	CDM, CDMV	●	●	●	●	●	●	●	●	●	●		200 to 1400	33000	300	3	80	19	
	CDKTV				●								500 to 1500	20000	100		100	19	
Multi-Stage Pumps	MSH	●	●	●					●				100 to 300	1500	750			21	
	MSH-T	●	●	●					●				200 to 350	3000	800			21	
	MHH	●	●	●					●				150 to 300	800	800			21	
	MHA								●				125 to 200	800	800			21	
	MMK		●	●									40 to 350	1000	150	5.4	230	21	
	MML		●	●					●				40 to 350	1000	500	5.4	230	21	
	MMO		●	●									32 to 65	130	400	4	140	22	
Mixed-Flow Pumps	SPV	●			●	●	●	●		●			300 to 2800	80000	100		80	23	
	SPSY	●	●					●					350 to 1200	20000	50			23	
Submersible Pumps	SMIV	●											400 to 700	4500	6			25	
	SMSV	●											400 to 700	4200	14			25	
	SMV	●											150 to 1000	9000	70			25	
	F/TB	●											25 to 250	400	200			26	
	F/VC, F/VD F/UW, F/SP	●											40 to 300	660	90			26	

Desalination



Torishima has met the challenge of those demands and has supplied pumps for a wide range from low to high pressure applications for all desalination processes, MSF, MED and RO, for 40 years. There are now over 3000 pumps operating in desalination plants in about 30 countries around the world. Our global desalination projects include some of the largest desalination plants currently in operation.

Sewerage, Agriculture, Irrigation and River Water

Torishima provides innovative and efficient water management solutions for sewerage, agriculture, irrigation, and river water industries. Committed to sustainability, water security, and environmental protection, we optimize water distribution for agriculture, urban sanitation, and resource management. Our advanced pumping technology supports global sustainable growth and community resilience.



Sewerage, Agriculture, Irrigation and River Water



Chart for selecting Pumps by Application

Main Application: Horizontal, Vertical, Horizontal/Vertical
 Secondary Application: Horizontal, Vertical, Horizontal/Vertical

Products	Applications								mm	m³/h	m	MPa	°C	Page
	Sewerage Transfer Plant	Sewerage Disposal Plant	Sludge Disposal Plant	Storm Water Drainage	Small Capacity Sewerage	Agriculture	Drainage	Irrigation, Sprinkler						
End-Suction Pumps	CAL						●	●	32 to 300	600	150	1	80	15
	CAM						●	●	32 to 250	1200	150	1.6	80	16
	CE						●	●	200 to 300	2100	90	1	140	10
	CFV	●		●	●		●	●	150 to 5000	15000	100			17
	CFV-SM	●			●				200 to 600	3000	50			17
	CNA		●	●		●			50 to 200	800	70	1	140	17
	CNP		●	●					50 to 250	850	100	1	250	18
Double-Suction Pumps	CDM, CDMV	●			●		●	●	200 to 1400	33000	360	3	80	19
	MSH						●	●	100 to 300	1500	750			21
Multi-Stage Pumps	MSH-T						●	●	200 to 350	3000	900			21
	MMK						●	●	90 to 330	1000	150	5.4	230	21
	MML						●	●	90 to 330	1000	500	5.4	230	21
	MMO						●	●	32 to 85	130	400	4	140	22
Mixed-Flow Pumps	SP	●			●		●	●	400 to 2000	36000	9			23
	SPV	●	●		●		●	●	300 to 2800	60000	100		80	23
	SPS, SPSY						●	●	350 to 1200	20000	90			23
	SPSX						●	●	250 to 300	1380	17			24
Axial-Flow Pumps	IS				●		●	●	400 to 2000	36000	5			24
	ISV		●		●		●	●	400 to 4500	18000	5			24
Submersible Pumps	SMI, SMS						●	●	400 to 3500	21000	8			25
	SMIV				●		●	●	400 to 700	4500	6			26
	SMSV				●		●	●	400 to 700	4200	14			25
	T/B, T/C, T/N	●	●		●				90 to 800	4800	40		40	26
	F/TB						●	●	25 to 200	800	200			26
Miscellaneous Pumps	F/YC, F/YD, F/UW, F/SP						●	●	80 to 300	640	90			26
	SNK	●			●				400 to 3500	16000	10			28

Regional & Urban Development



At Torishima we deliver advanced and efficient pumping solutions for regional and urban development, supporting critical infrastructure such as intelligent buildings, district heating and cooling, airports, harbor facilities, parks, and resorts. Reliable water management is essential for sustainable growth, public health and operational efficiency, and our pumping technology is designed to foster the development of resilient and prosperous cities and communities globally.



Regional & Urban Development

Chart for selecting Pumps by Application

Main Application: ● Horizontal ● Vertical ● Horizontal/Vertical
 Secondary Application: ● Horizontal ● Vertical ● Horizontal/Vertical

Products	Applications	Intelligent Building		District Heating and Cooling					Airport and Harbor Facilities			Park and Resort Facilities				mm	m ³ /h	m	MPa	°C	Page
		Air Conditioning	Water Supply and Drainage, Sanitation	Fire-Fighting	Cooling Water	Cold Water	Hot Water	Boiler Feed	Vacuum Supply Water, Raw Water	Water Supply	Drainage	Sewage Treatment	Water Supply	Drainage	Sewage Treatment	Fountains	Sizes	Max. Capacities	Max. Total Heads	Max. Operating Pressure	
End-Suction Pumps	CAL	●	●	●	●	●			●	●	●		●	●		32 to 200	600	100	1	80	15
	CAR	●	●		●	●			●	●	●		●	●		32 to 200	600	100	1	80	15
	CAM	●	●	●	●	●	●		●	●	●		●	●		32 to 250	1200	150	1.6	80	16
	CAS	●	●		●	●	●		●	●	●		●	●		32 to 250	1200	150	1.6	80	16
	CE	●	●	●	●	●			●	●	●		●	●		200 to 300	2100	90	1	140	16
	CNA		●									●		●		50 to 200	500	70	1	140	17
	CPC	●	●	●	●	●	●		●	●	●		●	●		32 to 250	1560	220	2.45	350	18
Double-Suction Pumps	CDM, CDMV		●													200 to 1400	33000	300	3	80	19
Multi-Stage Pumps	MMK	●	●	●				●		●		●				40 to 350	1000	150	5.4	230	21
	MML	●	●	●				●		●		●				40 to 350	1000	500	5.4	230	21
	MMO	●	●	●				●	●	●		●				32 to 65	130	400	4	140	22
Submersible Pumps	T/B, T/C, T/N		●							●	●		●	●		50 to 800	4800	40		40	26
	F/TB		●							●		●		●		25 to 200	400	200			26
	F/V, F/V, F/UW, F/SP		●							●		●		●		40 to 300	660	90			26
Miscellaneous Pumps	K/LP	●	●													25 to 100	84	60		100	27
	N/WR	●														15 to 80	72	300		90	27
	TE/O		●								●		●			25 to 200	300	40		40	28
	S/T	●			●	●				●		●		●		40 to 150	600	75	1	80	28

Chemical Industry



We provide innovative and efficient pumping solutions tailored for the chemical industry, ensuring safe, reliable, and precise fluid handling in critical applications. From chemical processing and petrochemicals to specialty chemicals and pharmaceuticals, our advanced technology supports operational efficiency, safety, and environmental sustainability. Committed to process optimization, regulatory compliance, and resource efficiency, our pumping systems enhance productivity while minimizing risks and environmental impact. With a focus on reliability and innovation, we empower the chemical industry to achieve sustainable growth and operational excellence worldwide.



Chemical Industry

Chart for selecting Pumps by Application

Main Application: Horizontal, Vertical, Horizontal/Vertical
 Secondary Application: Horizontal, Vertical, Horizontal/Vertical

Products	Applications										mm	m ³ /h	m	MPa	°C	Page			
	Petro-Chemical		Inorganic Chemical		Chemical Fertilizer		Fine-Chemical		Bio-Chemical								Oil and Coal Products		
	Process	Utility	Process	Utility	Process	Utility	Process	Utility	Process	Utility	Refinery	Coal Conversion	Sizes	Max. Capacities	Max. Total Heads	Max. Operating Pressure	Max. Operating Temperature		
End-Suction Pumps	CAL	●		●		●		●		●			32 to 200	600	100	1	80	15	
	CAR	●	●			●		●		●			32 to 200	600	100	1	80	15	
	CAM	●		●		●		●		●			32 to 250	1200	150	1.6	80	16	
	CAS	●	●			●		●		●			32 to 250	1200	150	1.6	80	16	
	CE	●		●		●		●		●			200 to 300	2100	90	1	140	16	
	CERS			●										32 to 100	300	98	1.4	340	16
	CNP	●		●		●							●	50 to 250	850	100	1	250	18
	CPC	●		●		●		●		●		●	●	32 to 250	1560	220	2.45	350	18
	CPR	●										●	●	25 to 400	2400	270	4	400	18
CPW			●										40 to 250	1440	200	6.3	280	18	
Double-Suction Pumps	CDM	●		●		●		●				●	200 to 1400	33000	300	3	80	19	
	MHB	●		●		●		●				●	80 to 200	2000	4200	42	200	20	
Multi-Stage Pumps	MHG, MHG-A	●		●		●		●				●	40 to 300	1400	4200	36	200	20	
	MHD	●		●		●		●				●	80 to 200	300	1200	14	180	20	
	MMK		●		●	●		●		●		●	40 to 350	1000	150	5.4	230	21	
	MML		●		●	●		●		●		●	40 to 350	1000	500	5.4	230	21	
	MMTV	●		●		●						●	40 to 400	2900	390	3.9	200	22	
Mixed-Flow Pumps	SPV		●		●		●		●				300 to 2800	80000	100		80	23	
Submersible Pumps	T/B, T/C, T/N		●			●		●					50 to 800	4800	40		40	26	
Miscellaneous Pumps	N/WR				●		●		●				15 to 80	72	300		90	27	

General Industry



We are proud to offer advanced and reliable pumping solutions for a wide range of applications in the general industry. The efficiency and quality of our products ensure optimum performance in diverse industrial operations, from manufacturing and processing to mining and construction.

Our commitment is to support the productivity and sustainability of industries around the world with innovative technologies and exceptional service.



General Industry

Chart for selecting Pumps by Application

Main Application: ● Horizontal ● Vertical ● Horizontal/Vertical
 Secondary Application: ● Horizontal ● Vertical ● Horizontal/Vertical

Applications	Products											mm	m ³ /h	m	MPa	°C	Page	
	Iron and Steel	Nonferrous Metal	New Materials			Motor Car Machinery Ceramics	Paper & Pulps	Food		Shipbuilding	Sizes							Max. Capacities
Products	Water Intake, Water Supply	Cooling Water	Descaling	Waste Water Treatment	Utility	Water Supply	Drainage	Process	Utility	Process	Utility	Dock Drainage						
End-Suction Pumps	CAL, CAR	●	●		●	●		●	●	●	●		32 to 200	600	100	1	80	15
	CAM, CAS	●	●		●	●		●	●	●	●		32 to 250	1200	150	1.6	80	16
	CE	●	●			●	●		●	●	●		200 to 300	2100	90	1	140	16
	CERS								●		●		32 to 100	300	98	1.4	340	16
	CNA							●		●			50 to 200	500	70	1	140	17
	CNP				●				●		●		50 to 200	850	100	1	250	18
	CPC					●	●			●	●	●	32 to 250	1560	220	2.45	350	18
Double-Suction Pumps	CPW								●		●		40 to 250	1440	200	6.3	280	18
	CDM	●	●			●		●	●		●		200 to 1400	33000	300	3	80	19
Multi-Stage Pumps	MHG, MHG-A			●		●							40 to 300	1400	4200	36	200	20
	MHD			●		●							80 to 200	300	1200	14	180	20
	MMK	●				●			●		●		40 to 350	1000	150	5.4	230	21
	MML	●				●			●		●		40 to 350	1000	500	5.4	230	21
	MMO	●				●			●		●		32 to 65	130	400	4	140	22
Specialized	HLV, HLAV					●							40 to 400	6000	180	32	420	22
Mixed-Flow Pumps	SPV	●	●		●						●		300 to 2800	80000	100		80	23
Submersible Pumps	S/M				●		●		●		●		40 to 350	1000	230			26
	T/B, T/C, T/N				●		●		●		●		50 to 800	4800	40		40	26
	F/TB	●							●		●		25 to 200	400	200			26
	F/V, F/VD F/UW, F/SP						●		●		●		40 to 300	660	90			26
Miscellaneous Pumps	N/WR					●					●		15 to 80	72	300		90	27
	TE/O				●		●		●		●		25 to 200	300	40		40	28
	O/PS							●		●			50 to 250	780	70			28

Main Pumps List

-  **End-Suction Pumps** P.15
-  **Double-Suction Pumps** P.19
-  **Multi-Stage Pumps** P.20
-  **Specialized Pumps** P.22

-  **Mixed-Flow Pumps** P.23
-  **Axial-Flow Pumps** P.24
-  **Submersible Pumps** P.25
-  **Miscellaneous Pumps** P.27

End-Suction Pumps



CAL (Cast Iron), CAR (Stainless Steel) 10bar end-suction volute pump

We call CAL and CAR the Eco-Pumps which are eco-friendly semi-ordered standard pumps applying the state of the art technology of our large-sized high-efficiency engineered pumps.

The big features of CAL and CAR:

- 1) CFD (Computational Fluid Dynamics) optimized casing design ensures smooth fluid flow.
- 2) Three dimensional curved impeller optimizes smooth fluid flow.
- 3) Meeting customer's specification by impeller cut.
- 4) Excellent parts interchangeability

Applications

Feed / Drainage water for general industries,
Feed / Drainage water / Various processes for chemical / food industries,
Water intake / Distribution / Supply for water works,
Water pumping, Fire-fighting, Industrial water,
Cold / Hot water circulation in district heating / cooling plants, etc.

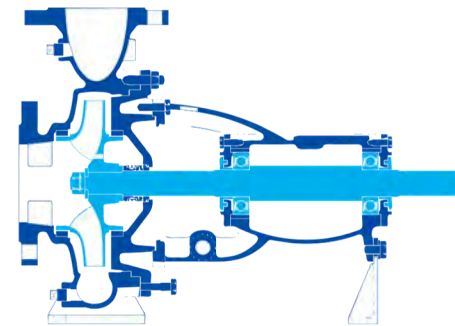
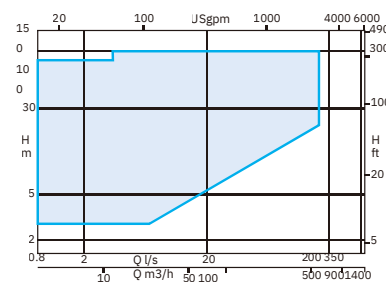

CAM (Cast Iron), CAS (Stainless Steel) 16bar end-suction volute pump

In common with CAL and CAR as CA series, CAM and CAS are totally optimized design pumps which adopt the efficient impeller design.

Applications

Feed / Drainage water for general industries,
Feed / Drainage water / Various processes for chemical / food industries,
Cold / Hot water circulation in district heating / cooling plants,
Water intake / Distribution / Supply for water works,
Water pumping, Fire-fighting, Industrial water, etc.

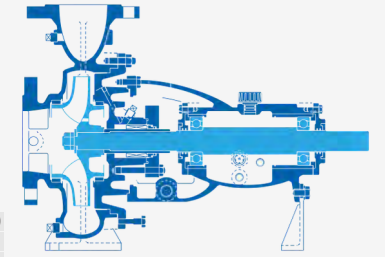
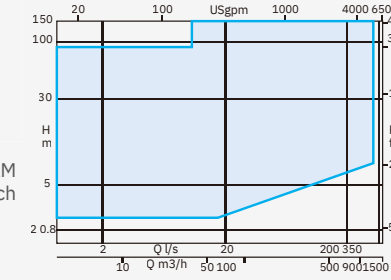

CBR

End-suction volute pump for ERD booster

Centerline pump foot mounted.
Used as booster pump for SWRO desalination and energy recovery purpose.

Applications

ERD booster pumps for high pressure line in RO desalination plants

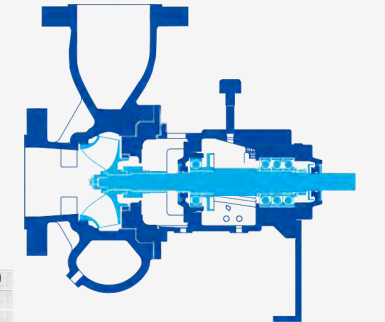
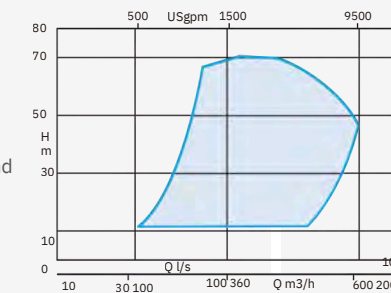

CE

End-suction volute pump

A single- or two-stage end-suction volute pump.
Various materials and structural designs employed to meet specification requirements for a variety of applications from fresh water, chemicals and heat transfer.

Applications

Water intake / Distribution / Supply / Boosting / Clarification for water works,
Various processes for chemical industries,
Water pumping / Drainage for agriculture,
Boiler feed pump,
Heat medium circulation,
Heater drain, etc.

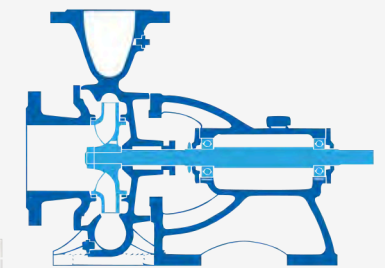
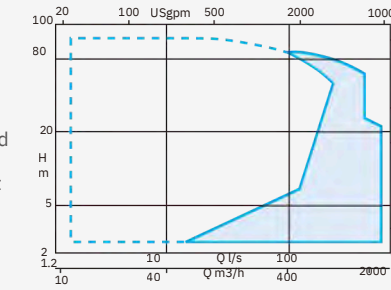

CERS

End-suction volute pump for heat transfer oil

Specialized for heat transfer oil.
Effective air-cooled design leads to no requirement for cooling at shaft sealing or bearing to 340°C heat transfer oil.

Applications

Dry / Agitator / Heating systems for chemical industries,
Oven / Dry / Heating systems for food industries,
Dry / Heating systems for general industries, etc.

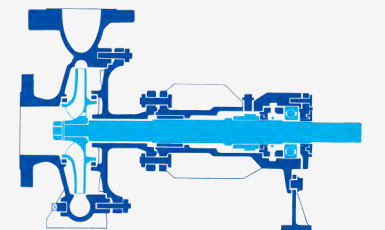
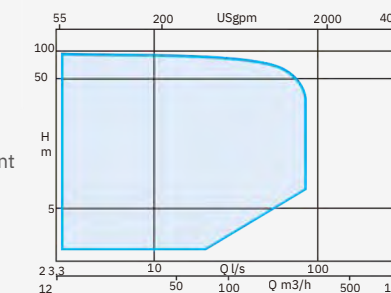

CFV

Vertical mixed - flow volute pump

Applicable for wide range from low head to high head. Suitable for relay pumps in sewage treatment facilities.

■Applications

Sewage transfer, Rain water drainage, Water intake / Distribution / Boosting for water works, Water pumping / Drainage for agriculture, etc.

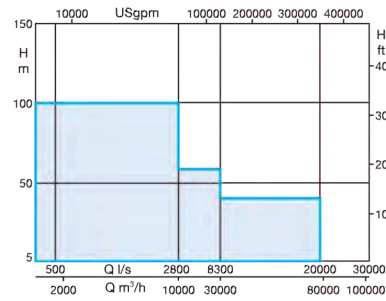

Capacity	120 to 72,000 m³/h / 790 to 317,000 USgpm
Total Head	5 to 100 m / 16 to 320 ft
Size	200 to 3,000 mm

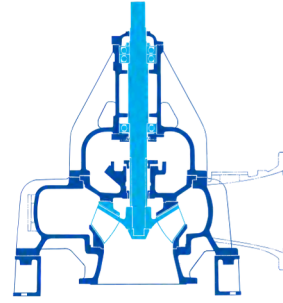

CFV-SM

Vertical mixed - flow volute pump with motor

CFV-SM is a pump with a submersible motor, which prevents outage during floods. No intermediate shaft between a motor and a pump is needed. The equipment is consolidated in one pump room, which allows simple facility and reduces operation and maintenance costs.

■Applications

Sewage transfer, Rain water drainage, Water intake / Distribution / Boosting for water works, Water pumping / Drainage for agriculture, etc.

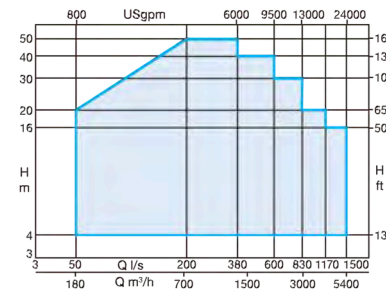

Capacity	180 to 5,400 m³/h / 790 to 13,200 USgpm
Total Head	4 to 50 m / 13 to 160 ft
Size	200 to 800 mm

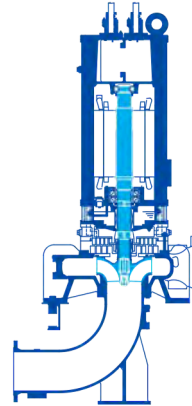

CHR

End-Suction volute pump for hot water circulation

Applicable mainly for hot water circulation of forced-circulation boilers. The forced cooling system is applied to the bearing bracket, stuffing box and base plate.

■Applications

Hot water circulation for forced-circulation boilers in thermal power plants, Petrochemical industries, Coal gasification plants, Oil refinery, etc.

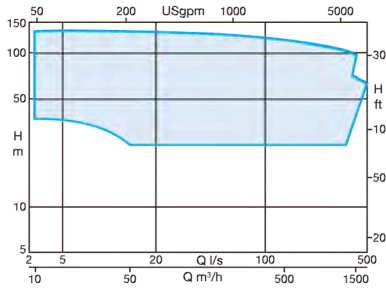

Capacity	up to 1,940 m³/h / 8,530 USgpm
Total Head	up to 125 m / 410 ft
Temperature	up to 325°C / 615°F
Pressure	up to 10.8 MPa / 108 bar / 1,560 psi
Size	50 to 300 mm

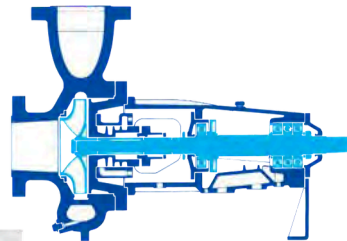

CNA

Non-clogging end-suction volute pump

The discharge opening of the non-clogging impeller is produced especially wide to permit free passing of any solids measuring 50 to 70% of the pump nozzle size.

■Applications

Sewage transfer, Transfer / Drainage of liquids containing sludge for general industries, Transfer of grain and water mixtures, Transfer of cellulose pulp of less than 2.5% B.D. free from air, etc.

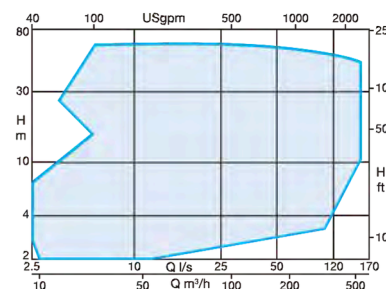

Capacity	9 to 500 m³/h / 39 to 2,200 USgpm
Total Head	up to 70 m / 230 ft
Temperature	up to 140°C / 280°F
Size	50 to 200mm

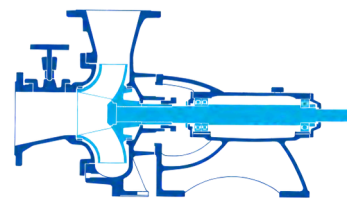

CNP

Non-clogging End-suction volute pump

Five kinds of standardized impellers available according to liquid. Applicable in various industries. The back pull-out structure and high interchangeability of this pump providing ease of maintenance.

■Applications

Transfer of corrosive liquids / abrasive liquids / chemical drainage including rough mixtures for chemical industries, Transfer / Drainage of solid mixtures for food / general industries, etc.

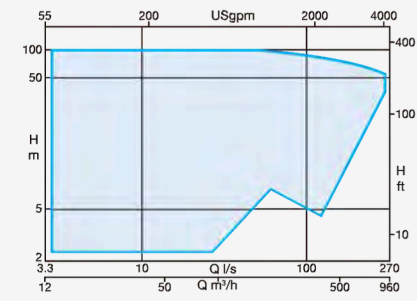

Capacity	up to 850 m³/h / 3,740 USgpm
Total Head	up to 100 m / 320 ft
Temperature	-30 to 250°C / -20 to 480°F
Size	50 to 200mm

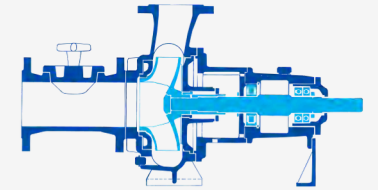

CPC

End-suction volute pump for process

Conforms to ISO2858. A wide range of structural designs of material and seals meet various specification requirements as process pump for chemical and general industries.

■Applications

Cooling systems / Water feed for deaerator / Condensate / Drain for energy industries, Processes for petrochemical / chemical industries, Water feed / Drainage for general industries, District cooling and heating, Water pumping, Fire-fighting, etc.

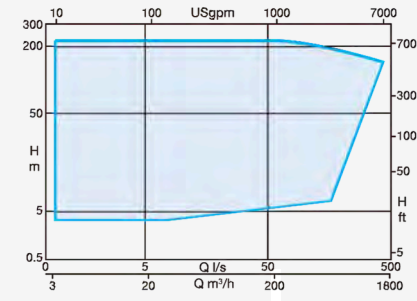

Capacity	up to 1,560 m³/h / 6,860 USgpm
Total Head	up to 220 m / 720 ft
Temperature	up to 350°C / 660°F
Pressure	up to 2.45 MPa / 24.5 bar / 355 psi
Size	32 to 250 mm

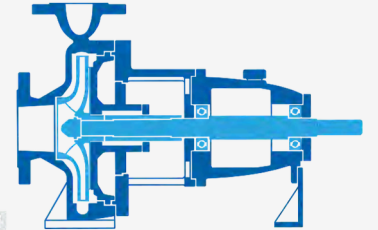

CPRD

End-suction volute pump for process

Simple and durable design providing high reliability. Widely used for oil refinery, petro-chemical, and general industries. Series with inducer for low NPSH req. also available.

■Applications

Processes for oil refinery / petrochemical / general industries

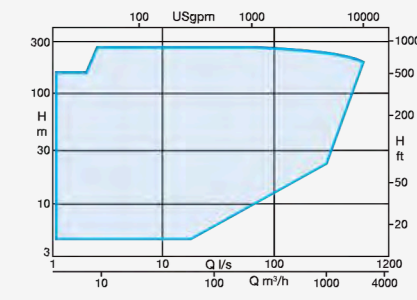

Capacity	up to 2,400 m³/h / 10,560 USgpm
Total Head	up to 270 m / 885 ft
Temperature	-70 to 400°C / -150 to 750°F
Pressure	up to 4 MPa / 40 bar / 580 psi
Size	25 to 400 mm

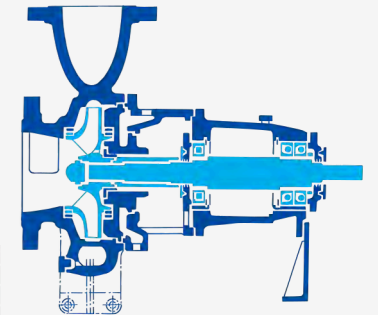

CPW

End-suction volute pump for hot water circulation

Centerline pump foot mounted. Mainly used as feed pump or circulation pump of hot water in large-size heating systems.

■Applications

Feed water / Circulation in high pressure hot water generating plants

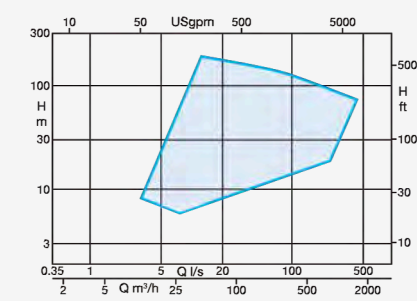

Capacity	up to 1,440 m³/h / 6,300 USgpm
Total Head	up to 200 m / 670 ft
Temperature	up to 280°C / 530°F
Pressure	up to 6.3 MPa / 63 bar / 910 psi
Size	40 to 250 mm

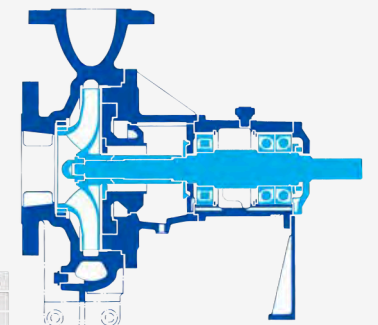

Double-Suction Pumps



CDM, CDM (Vertical)

Axially split double-suction pumpV

The world's most advanced high efficiency pump achieved by design to match the double suction and three-dimensional impeller with the latest hydraulics. Simple disassembly of upper half casing without disturbing pipe work enables ease of maintenance and inspection.

Applications

Water intake / Distribution / Boosting / Circulation / Drainage / Fire-fighting in energy industries, Cooling water circulation for district heating and cooling, Water intake / Distribution / Boosting for general industries, Water intake / Distribution / Water supply / Boosting for seawater desalination / water works / sewage, Irrigation for agriculture, Drainage, Pipe-line boosting, etc.

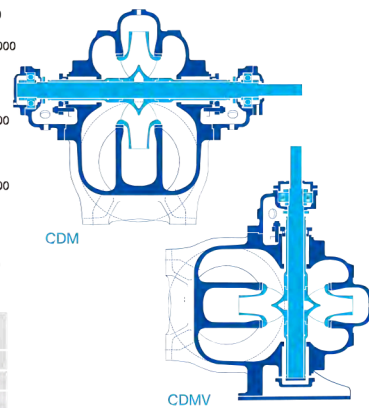
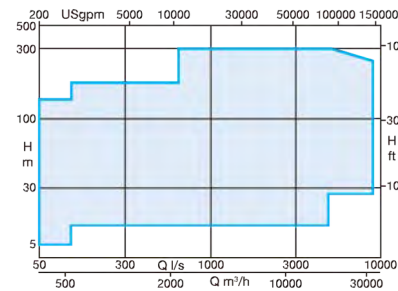

CDKY

Horizontal radially split double-suction pump

The rotating parts can be taken out by removing the side cover in axial direction. Suitable for handling high temperature and pressure liquids in chemical plants and power plants. CDKY mainly used as booster pump for boiler feed pump and hot water circulation pump.

Applications

Processes for power / chemical / pulp industries, etc.

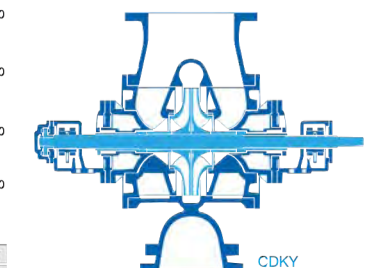
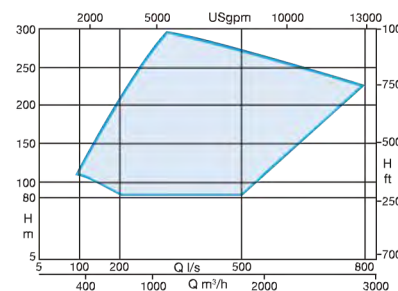

CDKTV

Horizontal radially split double-suction pump

The hydraulic design of the double-suction impeller offering low-shut off head, low NPSH and high speed. Mainly applicable for brine recirculation in seawater desalination plants and condensate in geothermal power plants when severe suction condition with large capacity and high head required.

Applications

Brine recirculation / Brine blow down for seawater desalination, Hot well / Large volume condensate in geothermal power plants

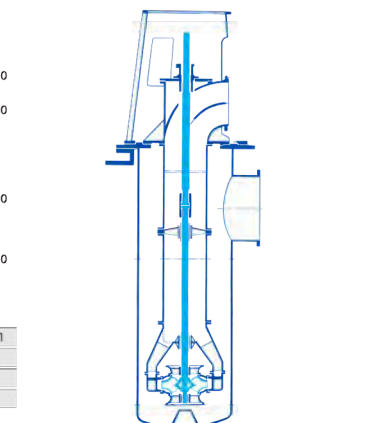
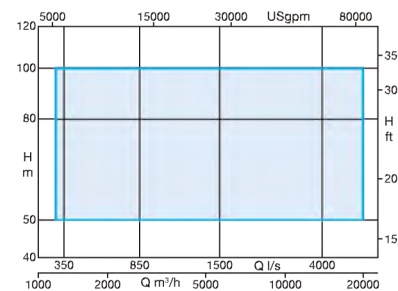

Multi-Stage Pumps



MHB

Radially split barrel casing pump

The barrel casing is fully welded to the pipe work and supported at its centerline on a fabricated steel base plate. The inner cartridge, which contains all pump components except the barrel and main stud bolts, is removable from the barrel as a complete unit for ease of maintenance.

Applications

Boiler feed in thermal power plants, High pressure feed water for various industries, etc.

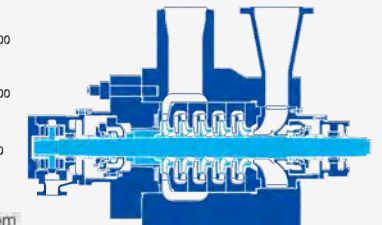
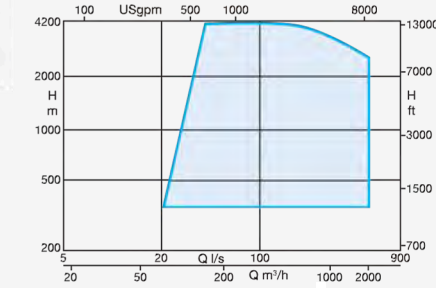

MHG, MHG-A

Horizontal multistage ring section pump

Radially split ring-section high-pressure multistage diffuser type pump. No warming through required enabling rapid start-up.

Applications

Boiler feed in power plants, High pressure feed water for various industries, etc.

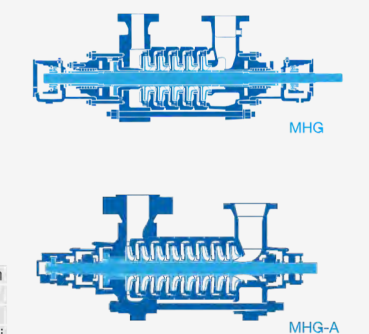
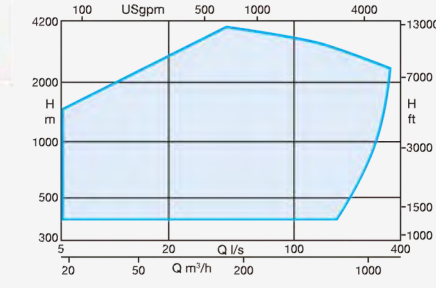

MHD

Horizontal multistage ring section pump

Radially split ring-section high-pressure multistage diffuser type pump achieving high efficiency and low NPSH. No warming through required enabling rapid start-up.

Applications

Boiler feed in power plants, High pressure feed water for RO desalination / various industries, etc.

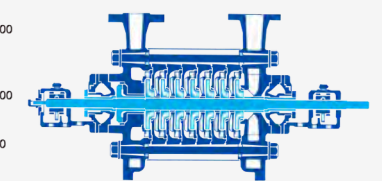
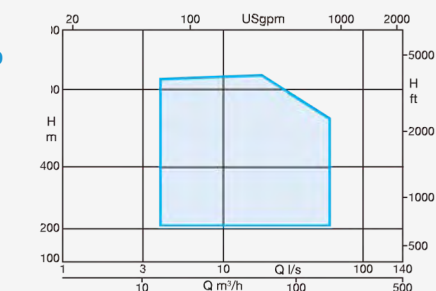

MSH, MSHT (Twin-Suction)

Horizontal axially split multistage volute pump

The axially split design offers ease of maintenance of rotating equipment without removing the lower casing. MSH-T covering high head range is twin-suction structure to satisfy high suction capability.

Applications
High pressure seawater feed for RO desalination, Distribution for water works, Water pumping for agriculture, etc.

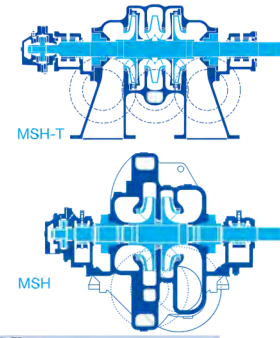
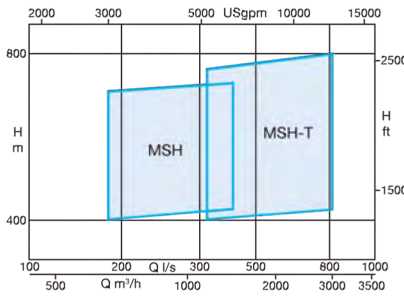

	MSH	MSH-T
Capacity	up to 1,500 m³/h / 6,600 USgpm	up to 3,000 m³/h / 13,200 USgpm
Total Head	up to 750 m / 2,460 ft	up to 800 m / 2,620 ft
Size	100 to 300 mm	200 to 350 mm

MHH

Axially split multistage pump

The axially split design offers ease of maintenance of rotating equipment without removing the lower casing. Applicable for high to low head duty by changing the number of stages.

Applications
High pressure seawater feed for RO desalination, Distribution for water works, etc.

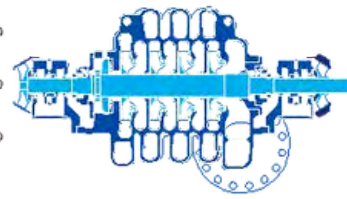
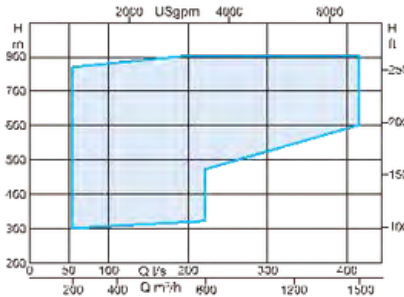

Capacity	up to 1,500 m³/h / 6,600 USgpm
Total Head	up to 800 m / 2,620 ft
Size	150 to 300 mm

MHA

Horizontal end-suction multistage ring section pump

Submerged bearing, radially split and compact design. The diffuser guides flow from impeller discharge to next impeller suction eye. The axial force is compensated by a hydraulic balancing device. The integrated design accumulated by high pressure and high speed pumps results in excellent cost performance and high efficiency.

Applications
High pressure seawater feed for RO desalination

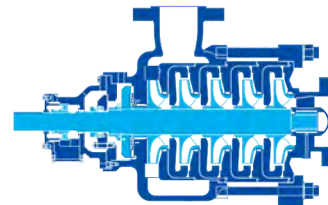
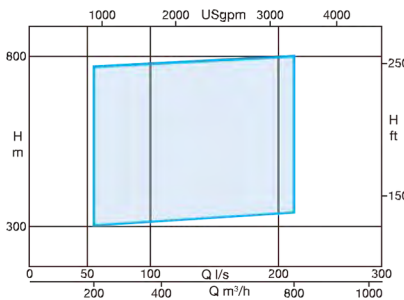

Capacity	up to 800 m³/h / 3,520 USgpm
Total Head	up to 800 m / 2,620 ft
Size	125 to 250 mm

MMK, MML

Horizontal multistage ring section pump

Axial thrust of MMK is balanced by the impeller balance holes, and by way of MML the balance disc, so that MMK and MML can operate with high reliability at high speed.

Applications
Boiler feed in power plants, High pressure feed water for various industries, Condensate for seawater desalination, Distribution / Boosting for water works, Irrigation for agriculture, etc.

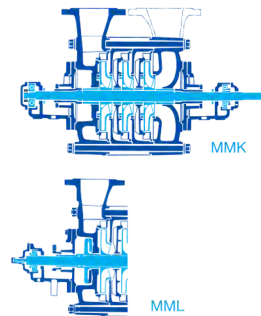
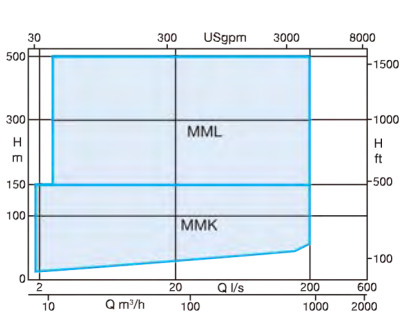

	MMK	MML
Capacity	up to 1,000 m³/h / 4,400 USgpm	up to 1,000 m³/h / 4,400 USgpm
Total Head	up to 150 m / 490 ft	up to 500 m / 1,640 ft
Temperature	up to 230°C / 440°F	up to 230°C / 440°F
Size	40 to 350 mm	40 to 350 mm

Multi-Stage Pumps

MMO

Multistage ring section pump

Compact and light-weight. Pump feet integrally cast onto bearing housings, allowing free orientation of both suction and discharge nozzles. No cooling of shaft seals required up to 140°C liquid.

Applications
Boiler feed / Condensate / Distribution for general industries, Water intake / Distribution / Water supply / Boosting for water works, Feed water / Drainage in building facilities, Cooling water / Hot and Cold water circulation, Water pumping / Drainage for agriculture

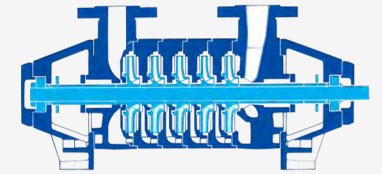
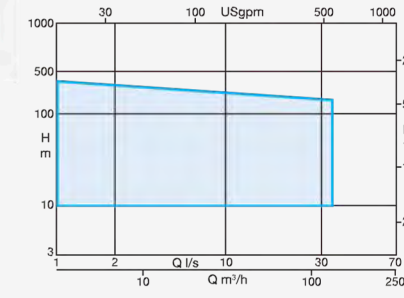

Capacity	up to 130 m³/h / 570 USgpm
Total Head	up to 400 m / 1,320 ft
Temperature	up to 140°C / 280°F
Size	32 to 65 mm

MMTV

Vertical multistage pump with canister

The high pressure vertical canister pump offers significant advantage in those cases where limited suction head is available. Applicable especially for condensers in power plants, desalination plants and other pipeline pumping applications.

Applications
Hot water / Condensate / High and low pressure drain in thermal power plants

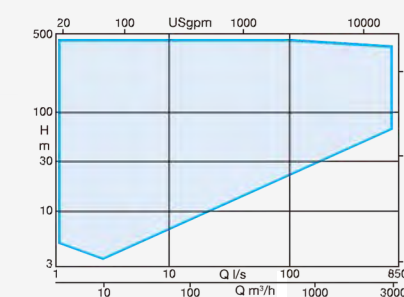

Ring casing type Bowl casing type

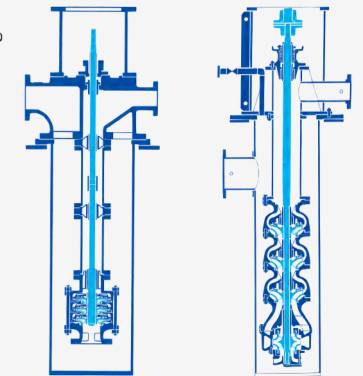

Capacity	up to 2,900 m³/h / 12,760 USgpm
Total Head	up to 390 m / 1,280 ft
Temperature	up to 200°C / 390°F
Pressure	up to 3.9 MPa / 39 bar / 565 psi
Size	40 to 400 mm

Specialized Pumps



HLV, HLA

Glandless(sealless) pump motor unit (Boiler circulation pump)

Pump and motor are integrated in a pressure-tight casing. The glandless design (no shaft seal) makes this pump best suited for pumping of high temperature and high pressure liquids without any leakage. Volute, annular or spherical casing designs optionally available.

Applications
Boiler circulation in super / sub critical power plants

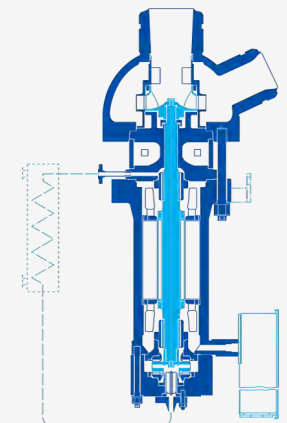
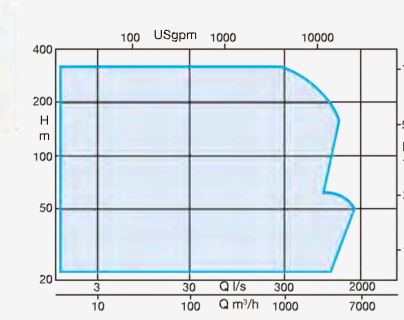

Capacity	up to 6,840 m³/h / 30,110 USgpm
Total Head	up to 320 m / 1,000 ft
Temperature	up to 420°C / 790°F
Pressure	up to 33 MPa / 330 bar / 4,790 psi
Motor Rating	up to 1,500 kW
Voltage	400V to 11 kV
Size	40 to 400 mm

Mixed-Flow Pumps



SP

Horizontal mixed-flow pump

Offering the highest efficiency in low head and large capacity range. The axially split design offering ease of maintenance of rotating equipment without removing the lower casing.

Applications

Water pumping / Drainage for agriculture,
Sewage transfer,
Rain water drainage,
Storm surge drainage, etc.

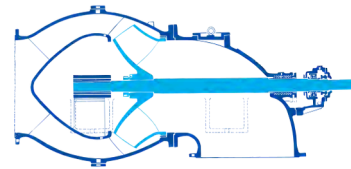
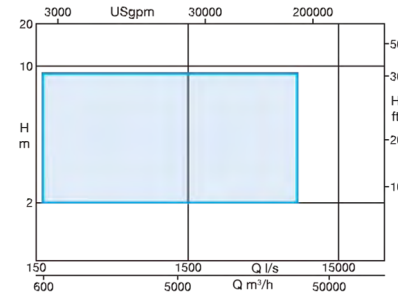

SPV, SPTV (Canister)

Vertical mixed-flow pump

Diffuser type, single or multistage design, mixed-flow impeller suspended within wet pit. Offering various hydraulic models, materials, and installation arrangement (above or below floor discharge) to suit the plant specific design.

Applications

Rain water drainage / Water intake for water works / sewage, Circulation / Cooling water / Condensate in power plants, Seawater intake / Brine recirculation for seawater desalination, Water intake / Cooling water for petro-chemical industries, Cooling water / Water intake / Dock

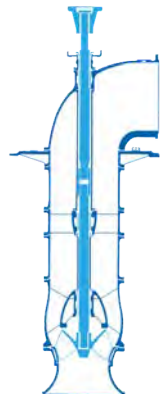
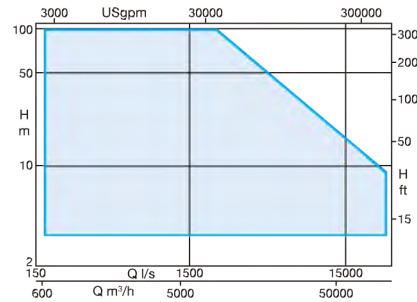

SPS, SPSY

Mixed-flow volute Pump

Suitable for fresh water and waste water pumping. Both open and closed type impeller available.

Applications

Distribution / Drainage for water works / sewage, Water pumping for agriculture, Cooling water in power plants, Seawater recirculation for seawater desalination, etc.

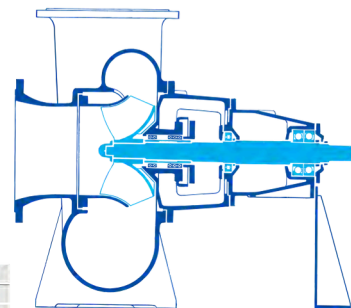
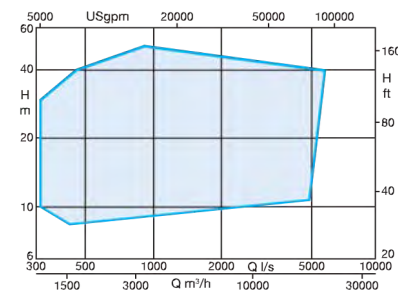

SPSX

Mixed-flow volute pump

Mainly used for water pumping and drainage for agriculture. Simple back pull-out structure allowing ease of overhaul.

Applications

Water pumping / Drainage for agriculture,
Drainage for civil engineering work,
Flood control, etc.

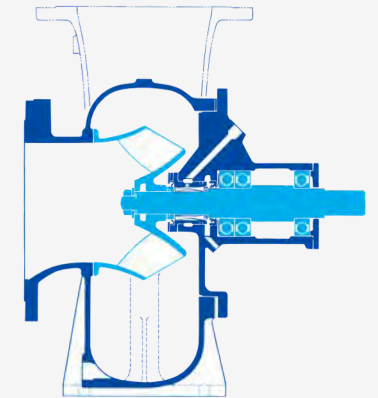
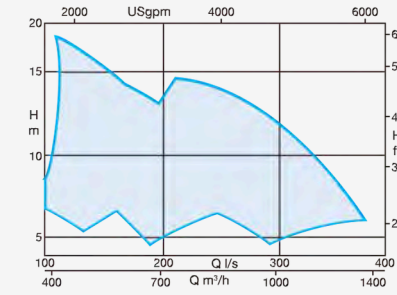

Axial-Flow Pumps



IS

Axial-flow propeller pump

Diffuser type, axial flow propeller suspended within wet pit. Offering various hydraulic models suitable for large capacity with low pump head of water. Axially split design offering easy maintenance without removing the lower casing.

Applications

Water pumping / Drainage for agriculture,
Sewage transfer,
Rain water drainage,
Storm surge drainage, etc.

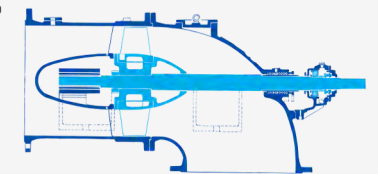
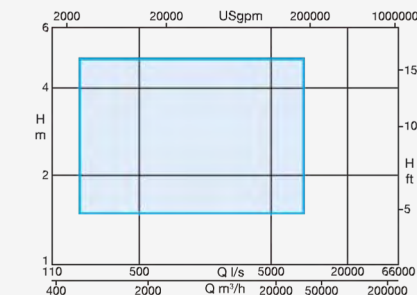

ISV

Vertical axial-flow propeller pump

Diffuser type, axial flow propeller suspended within wet pit. Especially used for large capacity with low head of water. The various hydraulic models applied to the change of the capacity and head.

Applications

Water pumping / Drainage for agriculture,
River water drainage,
Cooling water in power plants

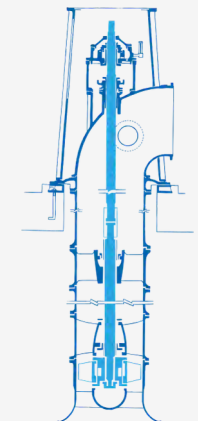
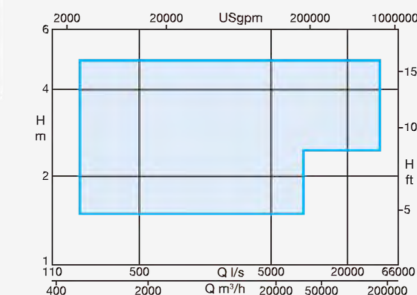

Submersible Pumps



SMI (Axial-Flow), SMS (Mixed-Flow) Tubular Pump

Horizontal tubular pump-units combining an axial-flow or mixed-flow pump and a dry-type electric motor in a single tube. Little noise and compact owing to the small water flow loss and the combined motor. Either connected directly to an electric motor or used with a reduction gear for slower rotation.

Applications
Water intake / Distribution / Drainage for water works, Water pumping / Drainage for agriculture, Industrial water / cooling water / drainage, Drainage for civil engineering work, etc.

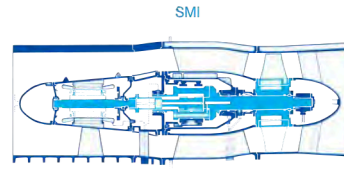
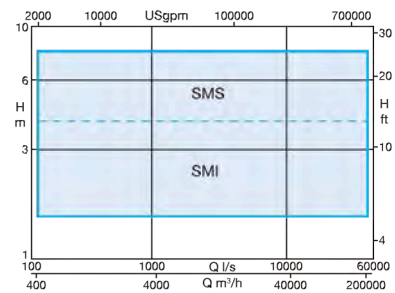

SMIV (Axial-Flow) SMSV (Mixed Flow) Dry-type submersible pump

Large capacity submersible propeller pumps with low head capabilities. Offering high efficiency and superior performance with compact design and easy operation. Designed to meet the requirements for efficient handling of large capacity of water. In particular, for installation, maintenance and inspection in pits, "Auto In-Pipe Column Installation type" adopted because of the high reliability and rapid discharge connections.

Applications
Water pumping for agriculture, River drainage, Rain water drainage, Water intake / Drainage for sewage, etc.

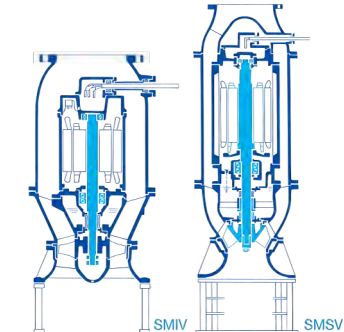
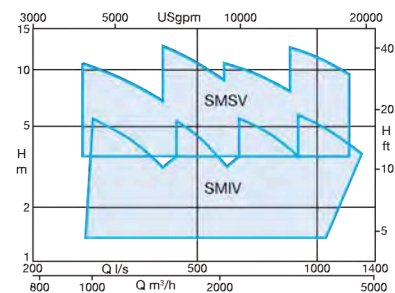

SMV, SMRV LARGO-Size submersible motor pump

SMV is vertical tubular casing pump with submersible motor. Water-filled or oil-filled type motor is provided. SMRV uses an oil-filled type submersible motor whose suction entry is located between motor and pump.

Applications
Water intake / Distribution / Drainage for water works, Water pumping / Drainage for agriculture, Industrial water / cooling water / drainage, Drainage for civil engineering work, etc.

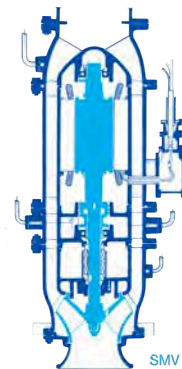
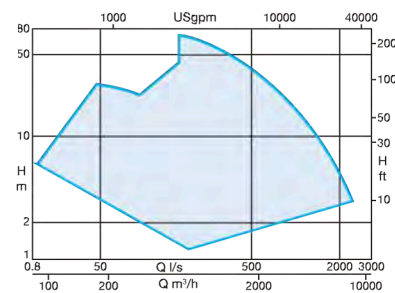

S/M

Dry type submersible motor pump

Small light-weight and easy to handle. Best suited for discharging waste water at construction sites and draining water in buildings and factories. The motor is equipped with an auto-cut device, submersion detection device and protection device. The impeller is made of wear resistant materials.

Applications
Waste water / Sludge drainage for civil engineering works, Drainage in factories, etc.

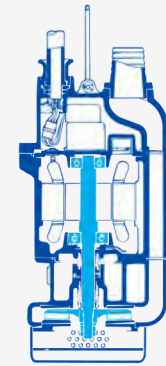
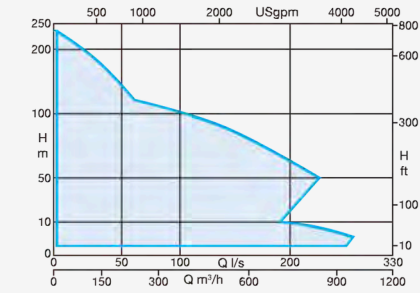

T/B, T/C, T/N Submersible motor pump

Wide ranges of impellers suited for all types of sewage and effluent, especially untreated sewage containing fibers, solid admixtures, sewage sludge, circulating sludge. Removable device for ease of maintenance and inspection also available.

Applications
Waste water / material drainage for sewage, Waste water / material drainage for construction facilities, Rain water drainage, etc.

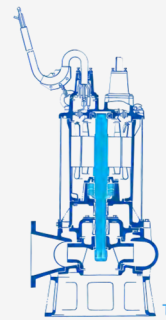
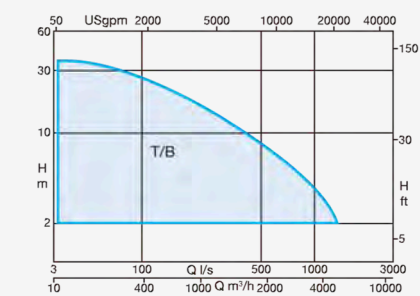

F/TB

Submersible motor pump for deep well

Vertical or horizontal submersible motor pumps with radial or mixed flow impellers, multi-stage. Water sealed three-phase induction motor is highly reliable electrically and mechanically as submersible motor, and enables less trouble and safe operation.

Applications
Water intake / Distribution / Water supply for water works, Water feed / Distribution for general industries, Water pumping for agriculture

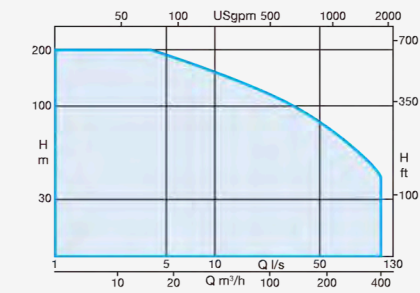

F/VC, F/VD, FUW, F/SP

Submersible motor pump for shallow well

Water sealed three-phase induction motor is adopted for submersible motor. Suction entry of F/VC and F/UW is located at the bottom and that of F/VD and F/SP is between pump and motor.

Applications
Water intake / Distribution / Water supply for water works, Water feed / Distribution for general industries, Water pumping for agriculture

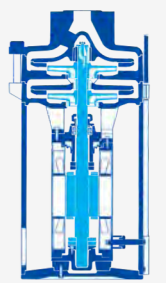
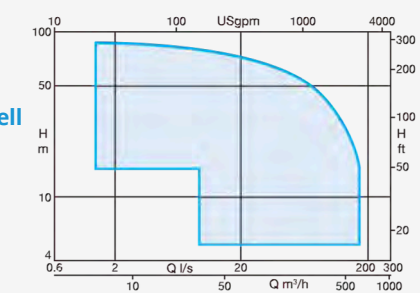

Miscellaneous Pumps



TE/O, TE/CO (Stainless Steel)

Self priming pump

No need for priming. Offering outstanding self priming performance and durability. Direct-connected motor is standard.

Applications
For industrial facilities, construction facilities, agriculture, waste water treatment, etc.

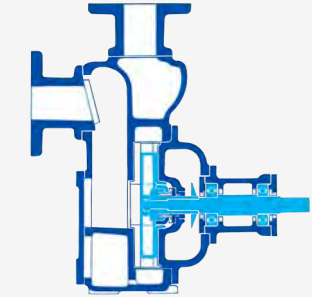
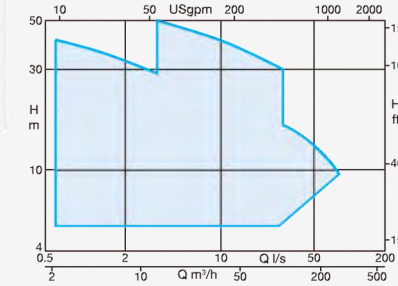

	TE/O	TE/CO
Capacity	up to 300 m³/h / 1,320 USgpm	up to 180 m³/h / 790 USgpm
Total Head	up to 40 m / 130 ft	up to 50 m / 160 ft
Temperature	0 to 40°C / 30 to 100°F	0 to 40°C / 30 to 100°F
Size	25 to 200 mm	25 to 125 mm

K/LP, K/SLP2 (Stainless Steel)

Line pump

Pump and 2-pole motor close coupled with common shaft. Line construction of suction entry and discharge fits in any position into a pipeline.

Applications
Water and hot water circulation in building facilities, Processes for various industries, General water feed, Boosting for water works, etc.

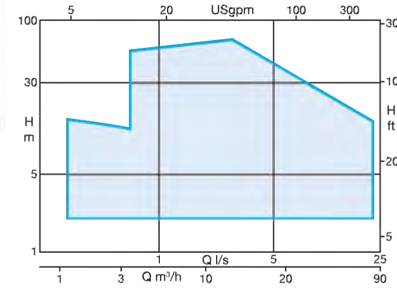

Capacity	up to 84 m³/h / 370 USgpm
Total Head	up to 60 m / 200 ft
Temperature	up to 100°C / 210°F
Size	25 to 100 mm

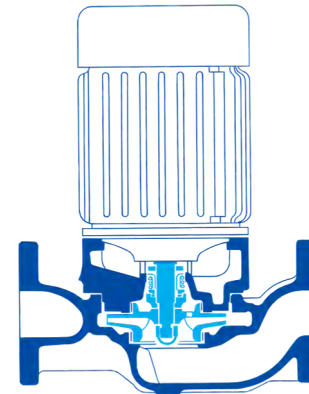

O/PS

Pulp pump

Suitable for pumping slurry and pulp stocks up to 5% consistency. The impeller is Mixed flow type allowing the pump to be used for a wide range of applications.

Applications
Pulp liquid transfer for paper / pulp industries, Solid transfer / drainage for general industries, Fruit or cereal and water mixture transfer for food industries, etc.

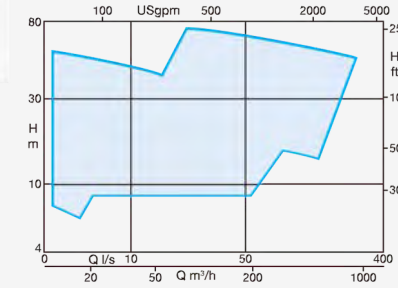

Capacity	up to 780 m³/h / 3,430 USgpm
Total Head	up to 70 m / 230 ft
Size	50 to 250 mm

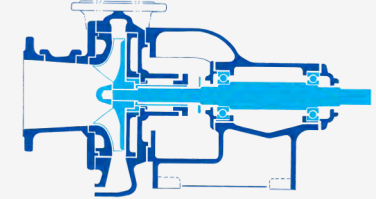

N/WR

Wesco pump

Specially-shaped impeller revolves at high speed in casing, makes the flow and absorbs up. Extremely small impeller clearance due to the use of a special method of fixing and special materials to assure high stability. Best suited for applications with small capacity and high head.

Applications
Water feed / pumping for general industries, Chemical liquid transfer, Various fuel oil transfer, High pressure boiler feed, High pressure washing, etc.

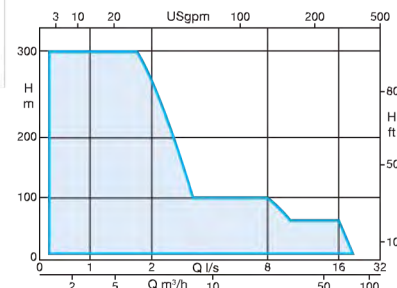

Capacity	up to 72 m³/h / 310 USgpm
Total Head	up to 300 m / 980 ft
Temperature	up to 90°C / 190°F
Size	15 to 80 mm

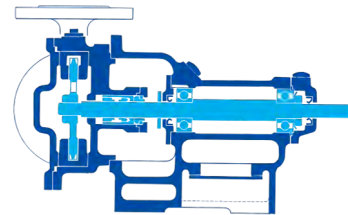

SNK

Screw Pump

Suitable for pumping liquids containing small stones, other suspended solids or rags, pieces of wood or ropes, digested or activated sludge etc. The simple, rugged construction and the open screw trough facilitate maintenance and inspection.

Applications
Water pumping for treatment plants, Water pumping / Drainage for agriculture, Return sludge for sewage treatment plants, Waste water transfer, etc.

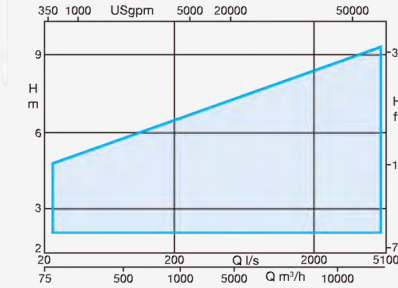

Capacity	up to 18,000 m³/h / 79,250 USgpm
Total Head	up to 10 m / 32 ft
Size	400 to 3,500 mm

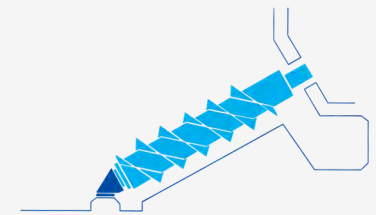

NVS, NVD

Vacuum pump

The rotating, water-sealed pump sucks and exhausts gas using the centrifugal force of the liquid. Continuous gas exhaustion is made without vibration and in complete safety even when water enters in the pump interior during operation.

Applications
Pump water priming, Gas exhaustion / Vacuum generation / Pressure-feeding for chemical industries

Air Capacity	up to 72 m³/min
Negative Pressure	up to 88 kPa
Size	20 to 100 mm

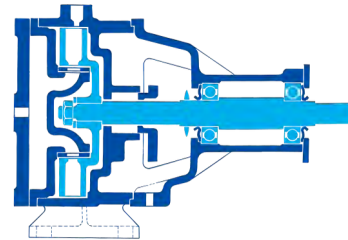

S/T

Vertical Volute Pump

Easy-installation close-coupled construction. Size 40 to 100mm back pull-out structure facilitates ease of maintenance.

Applications
Boosting / Water feed / Water pumping for general industries, etc.

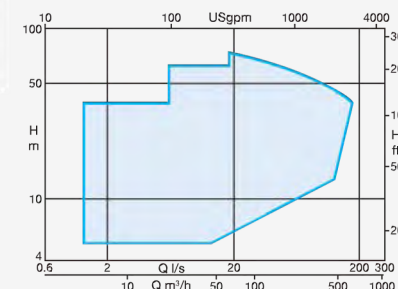

Capacity	up to 600 m³/h / 2,640 USgpm
Total Head	up to 75 m / 240 ft
Temperature	0 to 80°C / 32 to 176°F
Size	40 to 150 mm

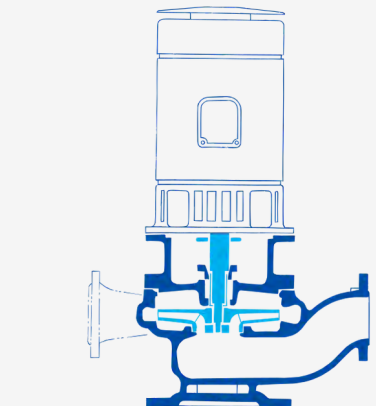

Committed to Pumps since 1919

Over a Century of Japanese Precision and Innovation – Evolving for a Better World

Sewerage, Agriculture, Irrigation and River Water



Regional & Urban Development



Power Industry



Water Industry & Desalination



Chemical Industry



General Industry



Torishima's Mechanical Seals



Established in 1919 as a pump manufacturer, Torishima was able to draw on our expertise in pumping technology to pioneer the research and development of mechanical seals in Japan in 1949. In our long history we have had vast experience within many main industries and applications such as Power Generation and Desalination to name only a few. Besides proven seal designs to suit our own pump range, we are also capable of offering seal retro-fits and upgrades for other brands and manufacture for various types of equipment OEM's. As an integrated pump and seal manufacturer, we understand the relationship between both and the important role the seal plays. Our constantly developing sealing technology is a testament to our commitment to providing reliability focused products and solutions to our valued customers globally.

Mechanical Seal Applications

Field and Application	Power Generation		Seawater Desalination				Water Works & Sewerage		Rivers, Agriculture & Irrigation			Chemicals & Petrochemicals		General Industry, etc.														
	Boiler feed pumps	Boiler circulating pumps	Condensate pumps	Cooling water pumps	High-pressure pumps	Water filtration pumps	Back wash pumps	Brine recirculation pumps	Brine blowdown pumps	Seawater intake pumps	Product water pumps	Water transmission & distribution pumps	Sewage treatment pumps	Stormwater drainage pumps	River drainage pumps	Agricultural pumps	Agricultural drainage pumps	Irrigation pumps	Process pumps	Feed water pumps	Cooling water pumps	Process pumps	Feed water pumps	Cooling water pumps	Electro-deposition paint pumps	Submersible pumps	Sand pumps	Hydraulic turbines
Rotating Single Spring Component Seals	LU1000																											
	HU2000 (Unbalanced type)																											
	HB2000 (Balanced type)																											
	LD1000 (Double seal)																											
Rotating Multi-Spring Component Seals	MU2000 (Unbalanced type)																											
	MB2000 (Balanced type)																											
	MT2700 (Balanced type)																											
Stationary Multi-Spring Component Seals	MB2500 (Balanced type)																											
	MT4100 (Balanced type)																											
Cartridge Seals	MB2704CN (Inside rotating type)																											
	MB2704CZ (Inside rotating type, with pumping ring)																											
	MB8500CN (Stationary inside type)																											
	MB8500CZ (Stationary inside type, with pumping ring)																											
	MB2400CN (Outside rotating type)																											
	MB2504CZ (Stationary inside type, with pumping ring)																											
Split Seals	MB2901 (Stationary balanced type, non-flushing)																											
	MU2922 (Stationary balanced type, dry running application)																											
	MT9200 (Stationary balanced type, dry running application)																											
Specialized Seals	For hydraulic turbines																											
	For submersible sand pumps																											



Committed to advancing industrial technology with innovative, efficient and reliable solutions.

Founded in 1919 in Osaka, Japan, Torishima is a specialist pump manufacturer and industrial service provider.

Our passion for the products and services we offer drives us to keep innovation at the heart of our business and to remain a leading company in the industry, evolving every day and aspiring to be indispensable to society.

[High Tech Pumps ↗](#)

[Service Solutions ↗](#)

[Sustainability ↗](#)

More than 100 years Driving Industrial Evolution